

PAMU CONNECTOR

Board-to-wire

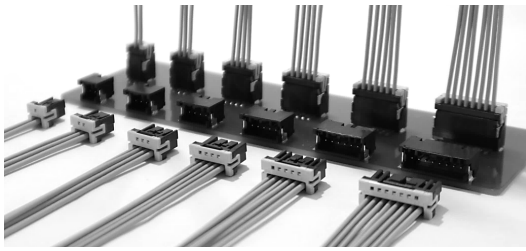

■ Features

- 2.0mm pitch, SMT type, Miniaturized connector for signal
- Half mating prevention structure (Inertial lock/Insertion with flat shape)
- Small size yet, stable contact resistance even under High temperature and vibration in automotive standards
- Socket contact has a high rigid box structure to protect a contact spring from external forces in any direction
- Improvement of harness workability due to contact spring protected shape
- Top/Side entry type
- Prevent incorrect mating by key codes
- Retainer available
- Housing lock lever protection function

Available in various fields as a MU (multi-use) connector with a mix of automotive and consumer characteristics.

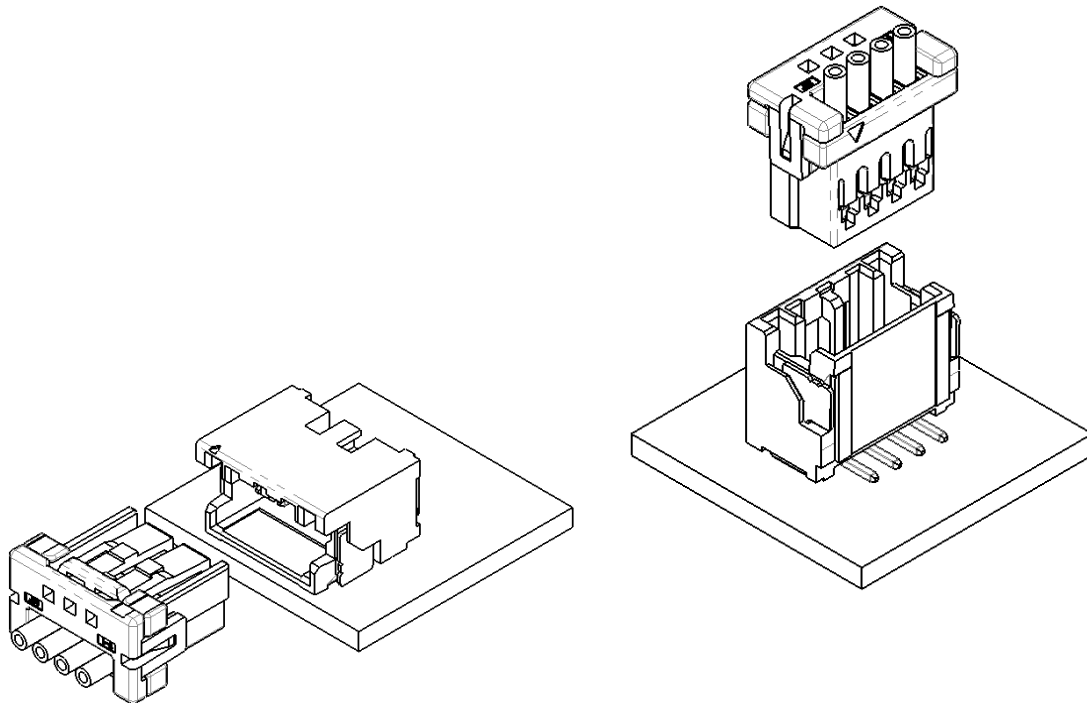

■ Specifications

Item	Standard	Condition
● Current rating	AWG#22 : 3A AC·DC AWG#26 : 1A AC·DC	When using single-circuit at the temperature of 23 ± 5°C.
● Temperature range	-40°C ~ +125°C	Including temperature rise in applying electrical current
● Applicable wire	Conductor / AWG#22 Coating OD / φ1.25mm ~ φ1.40mm	S barrel
	Conductor / AWG#26 Coating OD / φ1.30mm	SS barrel
● Contact resistance	Initial 10mΩ max After endurance 20mΩ max	DC 10mA
● Insulation resistance	100MΩ min	DC 500V
● Withstand voltage	No dielectric breakdown	AC 1,000V / min.

※ Compliant with ELV/RoHS2.
 ※ Contact JST for details.

Socket contact

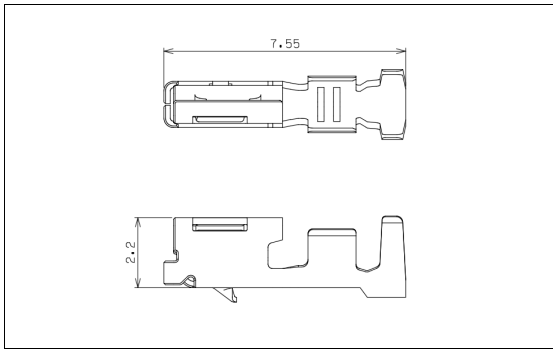

Size	Model No.	Applicable wire size		Q'ty/Reel
		Conductor AWG (mm ²)	Insulation O.D. (mm)	
S	SPAMU-01T-M0.5	#22 (0.30 to 0.35)	1.25 to 1.40	9,000
SS	SPAMU-002T-M0.5	#26 (0.13)	1.30	

Material and Finish

Copper alloy, tin-plated (reflow treatment)

Socket housing

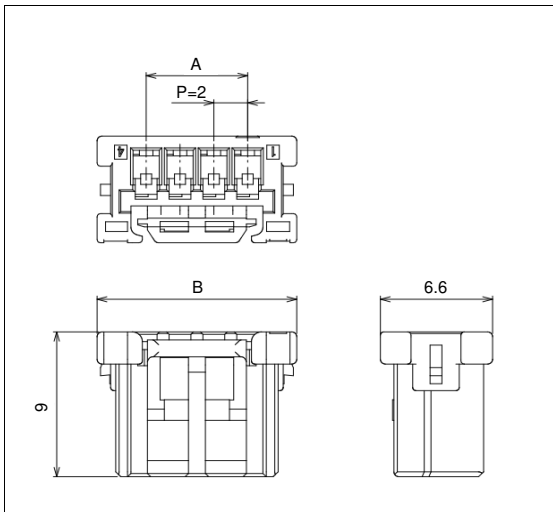

Circuits	Model No.	Dimensions (mm)		Q'ty/box
		A	B	
2	PAMURP-02V-K-A	2.0	7.8	20,000
3	PAMURP-03V-K-A	4.0	9.8	20,000
4	PAMURP-04V-K-A	6.0	11.8	10,000
5	PAMURP-05V-K-A	8.0	13.8	10,000
6	PAMURP-06V-K-A	10.0	15.8	10,000
8	PAMURP-08V-K-A	14.0	19.8	10,000

Material and Finish

Housing: Glass-filled PBT, Black

Note: Color/Key codes other than above-mentioned housing are also available.
Contact JST for details.

Retainer housing

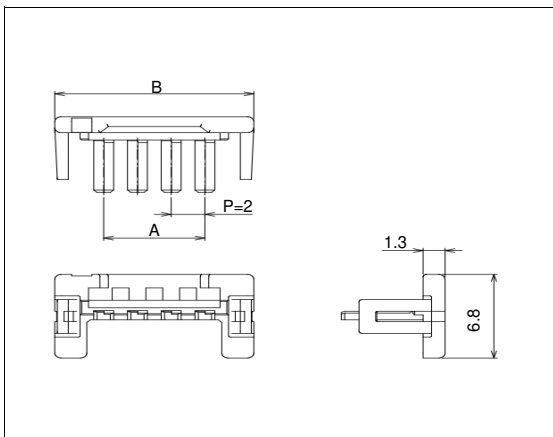

Circuits	Model No.	Dimensions (mm)		Q'ty/box
		A	B	
2	PAMUS-02V-LE	2.0	7.8	20,000
3	PAMUS-03V-LE	4.0	9.8	20,000
4	PAMUS-04V-LE	6.0	11.8	10,000
5	PAMUS-05V-LE	8.0	13.8	10,000
6	PAMUS-06V-LE	10.0	15.8	5,000
8	PAMUS-08V-LE	14.0	19.8	5,000

Material and Finish

Housing: Glass-filled PBT, Light blue

Male connector

Top Entry Type

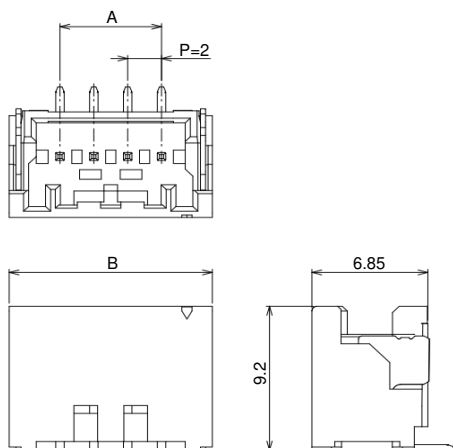

Side Entry Type

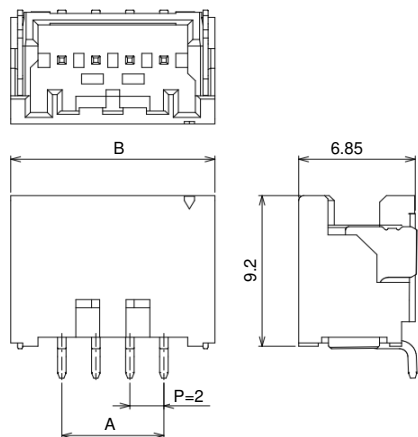

Circuits	Model No.	Dimensions (mm)		Q'ty/box
		A	B	
2	BM02B-PAMUK-A-*	2.0	8.0	4,500
3	BM03B-PAMUK-A-*	4.0	10.0	3,500
4	BM04B-PAMUK-A-*	6.0	12.0	3,500
5	BM05B-PAMUK-A-*	8.0	14.0	3,500
6	BM06B-PAMUK-A-*	10.0	16.0	3,500
8	BM08B-PAMUK-A-*	14.0	20.0	2,500

Material and Finish

Housing : Glass-filled PA, Black
 Solder tab : Copper alloy, tin-plated (Reflow treatment)
 Post : Copper alloy, tin-plated (Reflow treatment)

Note: Color/Key codes other than above-mentioned housing are also available.
 Contact JST for details.

(*) : TB...taping product

TBT...taping product with suction tape

Circuits	Model No.	Dimensions (mm)		Q'ty/box
		A	B	
2	SM02B-PAMUK-A-TF	2.0	8.0	6,300
3	SM03B-PAMUK-A-TF	4.0	10.0	4,900
4	SM04B-PAMUK-A-TF	6.0	12.0	4,900
5	SM05B-PAMUK-A-TF	8.0	14.0	4,900
6	SM06B-PAMUK-A-TF	10.0	16.0	4,900
8	SM08B-PAMUK-A-TF	14.0	20.0	3,500

Material and Finish

Housing : Glass-filled PA, Black
 Solder tab : Copper alloy, tin-plated (Reflow treatment)
 Post : Copper alloy, tin-plated (Reflow treatment)

Note: Color/Key codes other than above-mentioned housing are also available.
 Contact JST for details.

PC board layout

Top Entry Type

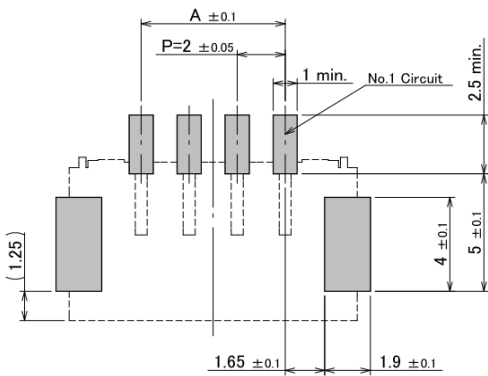

Circuits	Dimensions (mm)	
	A	
2	2.0	
3	4.0	
4	6.0	
5	8.0	
6	10.0	
8	14.0	

Side Entry Type

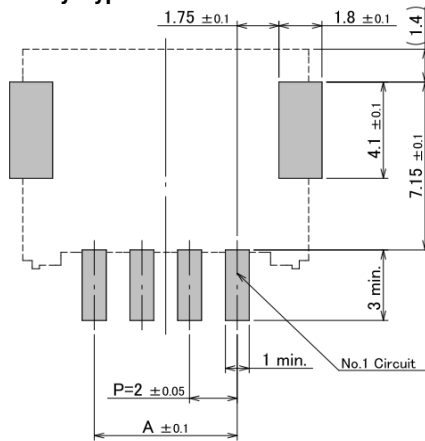

Circuits	Dimensions (mm)	
	A	
2	2.0	
3	4.0	
4	6.0	
5	8.0	
6	10.0	
8	14.0	

Assembly layout

Top Entry Type

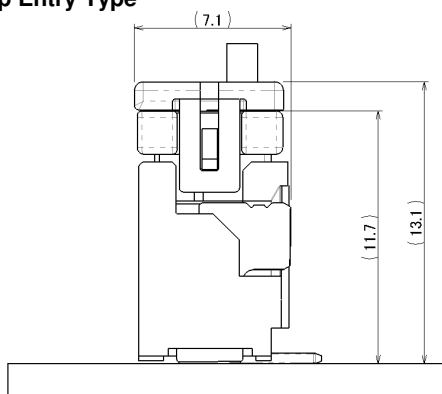

Side Entry Type

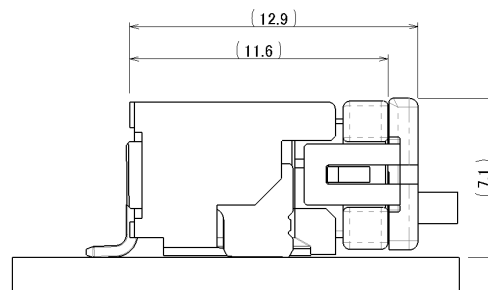

PAMU CONNECTOR

Keycode

Keycode		A	B
Housing color		Black	Natural
Configuration			
Socket housing		PAMURP-()V-K-A	PAMURP-()V-S-B
Base	Top entry type	BM()B-PAMUK-A-(*)	BM()B-PAMUS-B-(*)
	Side entry type	SM()B-PAMUK-A-TF	SM()B-PAMUS-B-TF

Note: Contact JST for details.

(*) :TB・・・taping product

TBT・・・taping product with suction tape

Crimping machine, Applicator

Strip terminal	Crimping machine	Applicator	Crimp applicator with dies
SPAMU-01T-M0.5	AP-K2N	MKS-L-10	APLMK SPAMU01-05
SPAMU-002T-M0.5			APLMK SPAMU002-05

Note: 1. Contact JST for details.

2. When crimping operation is conducted using an applicator and die set other than the above, JST cannot guarantee the performance of the terminal.