

Features

● Miniaturization and Low profile

0.50 terminal with 2.0 mm(W) X 2.5 mm(H) pitch is realized miniaturization and low profile.

Developed in pursuit of miniaturization and low profile as surface mounting type connector for automotive.
0.50 terminal with 2.0 mm pitch realized miniaturization.

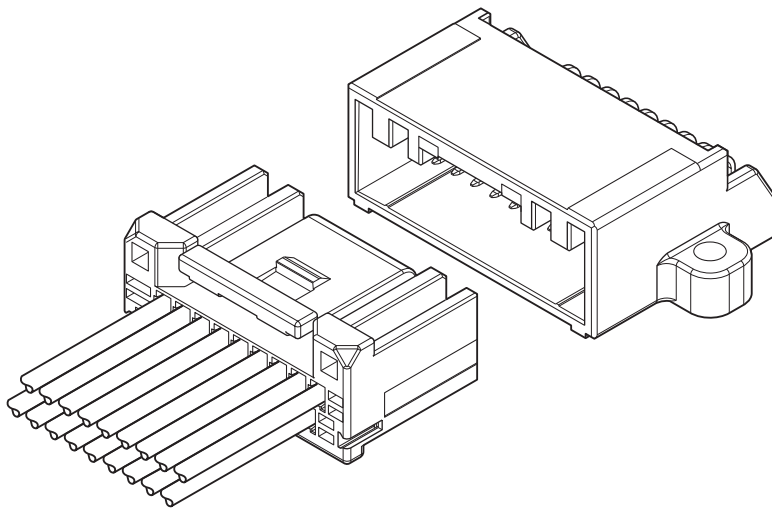

Specifications

- Current rating: 2 A AC, DC (0.3 mm²)
- Voltage rating: 14 V AC, DC
- Temperature range: -40°C to +125°C (gold-plated)
-40°C to +105°C (tin-plated)
(including temperature rise in applying electrical current)
- Contact resistance: Initial value/ 10 mΩ max.
After environmental tests/ 30 mΩ max.
- Insulation resistance: 100 MΩ min.
- Withstanding voltage: 1,000 VAC/minute
- Applicable wire: AESSX 0.3 mm², UL3265 0.3 mm²
(Equivalent to AWG#22, Insulation O.D. Φ1.5 mm max.)

* Compliant with ELV/RoHS.

* Contact JST for details.

Female terminal

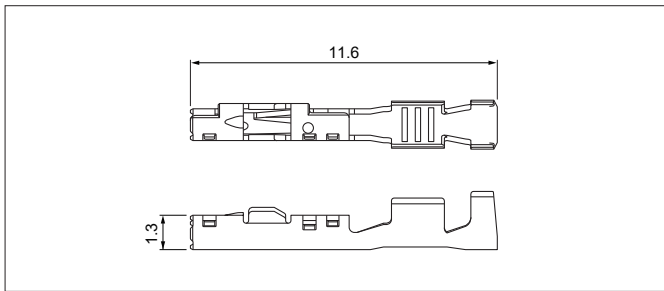

Model No.	Applicable wire range		Q'ty/reel
	Conductor (mm ²)	Insulation O.D. (mm)	
① SMEC-A021GF-M0.5	0.3	1.5 max.	10,000
② SMEC-A021T-M0.5			

Material and Finish

- ① Copper alloy, nickel-undercoated, Contact area; gold-plated
Barrel area; tin-plated
- ② Copper alloy, nickel-undercoated, tin-plated

Female connector

Single row

●5 circuits

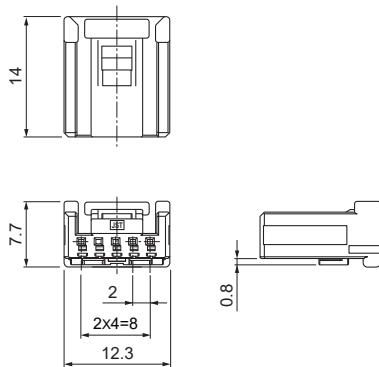

●8 circuits

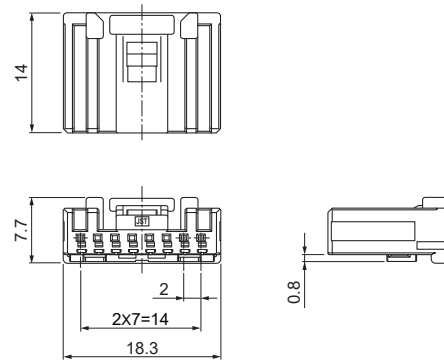

●10 circuits

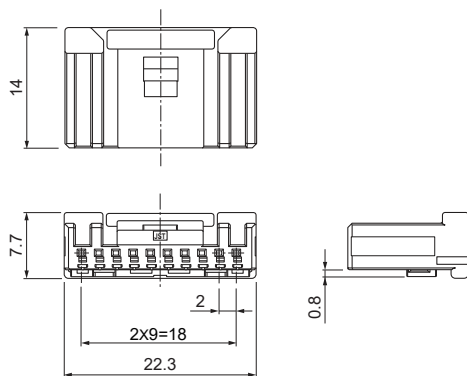

Type	Circuits	Model No.	Q'ty/box
Single row	5	05MEC-B-1A	400
	8	08MEC-B-1A	300
	10	10MEC-B-1A	200

Material and Finish

Housing: Glass-filled PBT, black
Retainer: Glass-filled PBT, blue

MEC CONNECTOR

Female connector

Dual row

● 10 circuits

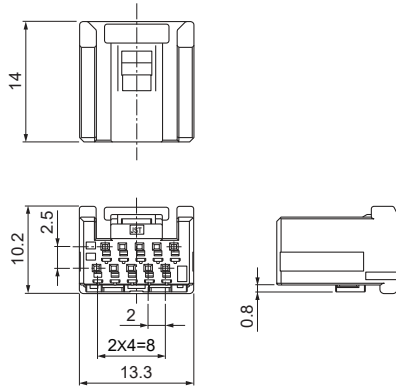

● 12 circuits

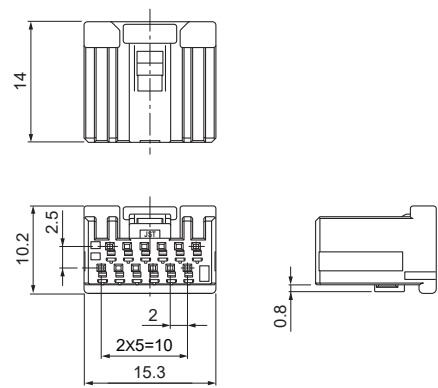

● 18 circuits

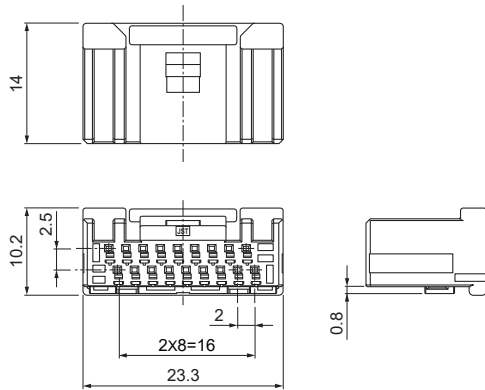

● 20 circuits

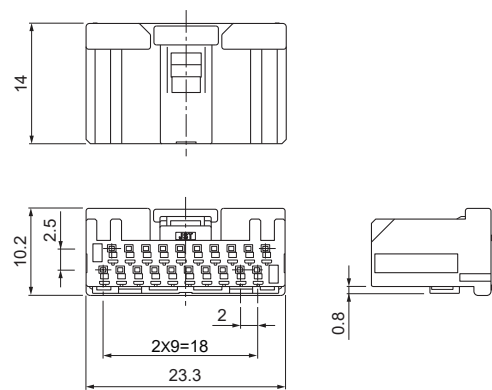

● 24 circuits

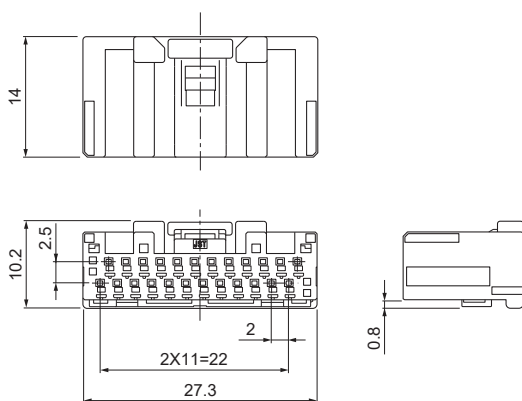

Type	Circuits	Model No.	Q'ty/box
Dual row	10	① 10MEC-B-2A	250
	12	① 12MEC-B-2A	200
	18	① 18MEC-B-2A	150
	20	Note) ② 20MEC-B-2A()	150
	24	① 24MEC-B-2A	100

Material and Finish

Housing: Glass-filled PBT, black

Retainer: ① Glass-filled PBT, blue

② Glass-filled PBT, natural (white)

Note: Color/Key codes other than above-mentioned housing are also available.
Contact JST for details.

Male connector

DIP type

Single row ● 5 circuits

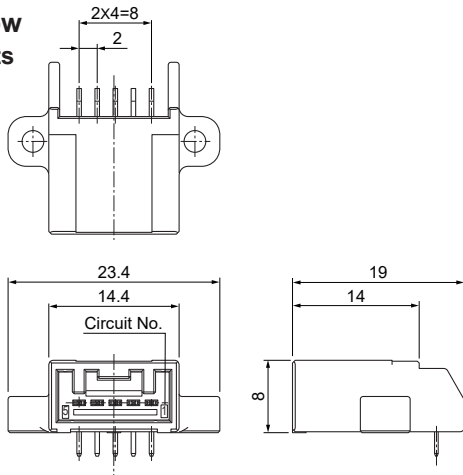

● 5 circuits (plugged up)

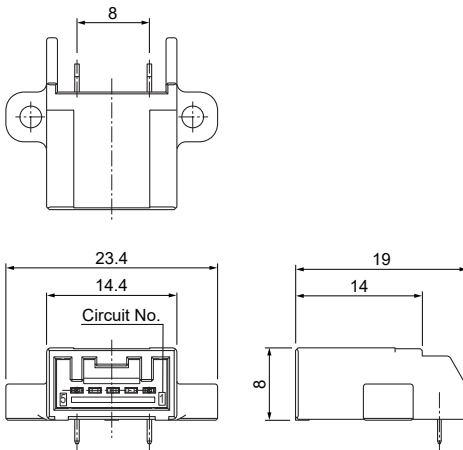

● 18 (10+8) circuits

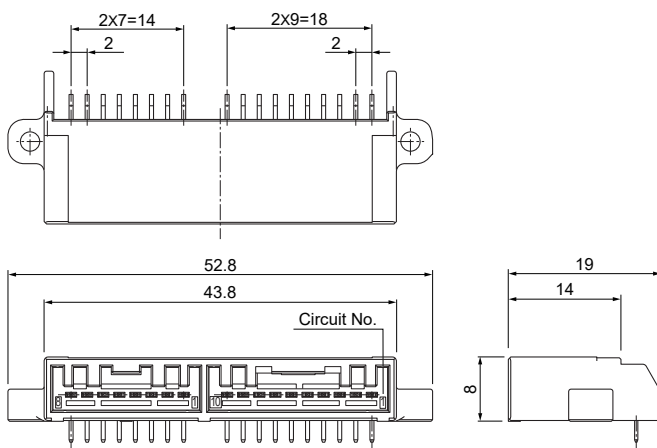

Dual row ● 10 circuits

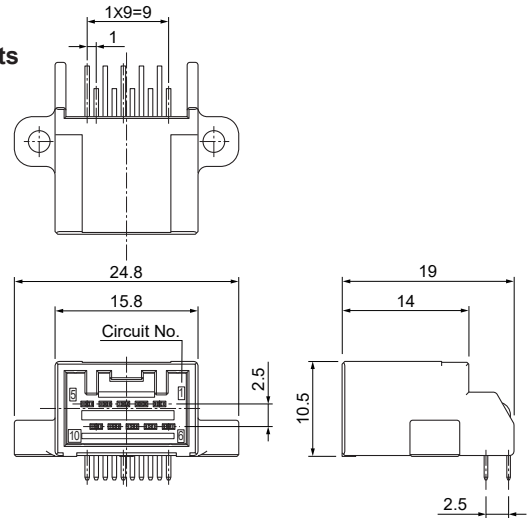

● 10 circuits (plugged up)

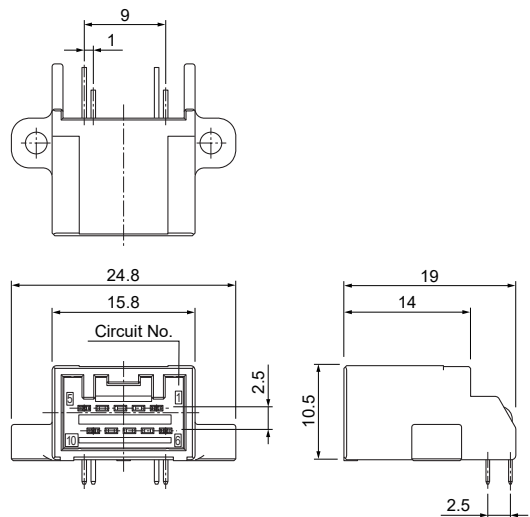

● 18 circuits

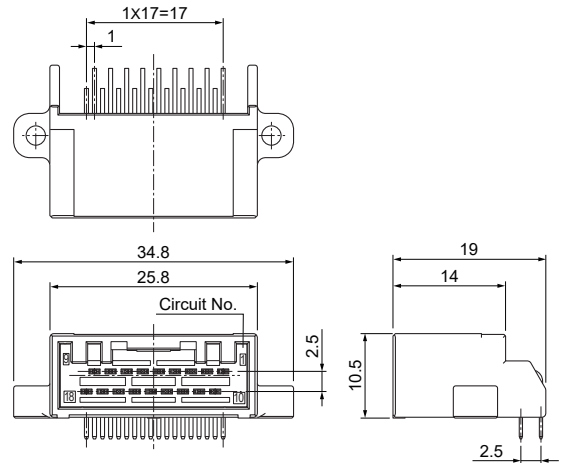

Type	Circuits	Model No.	Q'ty/box
Single row	5	S05B-MECK-1GA-A	700
	5	(Note) S05B-MECK-1GA-B	700
	18 (10+8)	S18B-MECK-1GA-A	350

Material and Finish

Housing: Glass-filled PBT, black
Terminal: Copper alloy, nickel-undercoated,
Contact area; gold-plated
Barrel area; tin-plated (reflow treatment)

Note: Plugged up

Type	Circuits	Model No.	Q'ty/box
Dual row	10	S10B-MECK-2GA-A	504
	10	(Note) S10B-MECK-2GA-B	504
	18	S18B-MECK-2GA-A	392

Material and Finish

Housing: Glass-filled PBT, black
Terminal: Copper alloy, nickel-undercoated,
Contact area; gold-plated
Barrel area; tin-plated (reflow treatment)

Note: Plugged up

MEC CONNECTOR

Male connector

SMT type

Dual row

● 10circuits

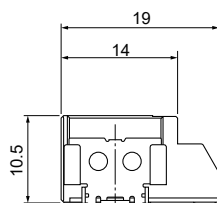
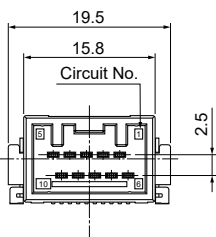
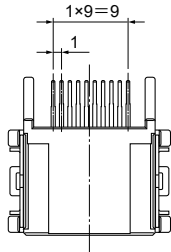

● 12circuits

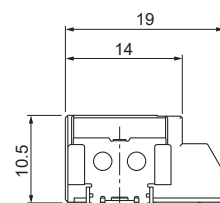
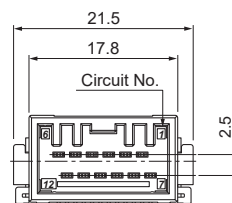
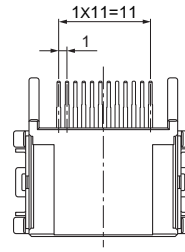

● 20 circuits

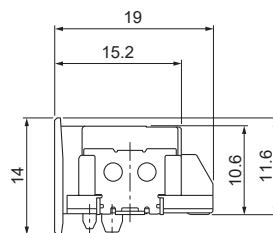
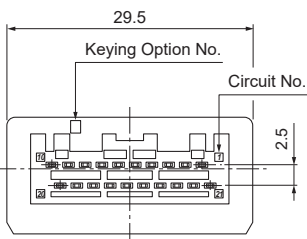
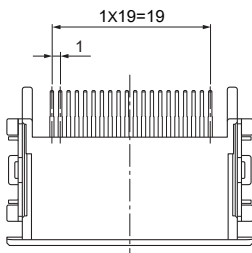

● 24 circuits

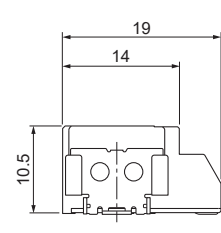
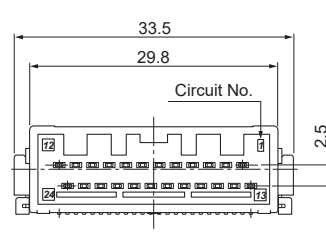
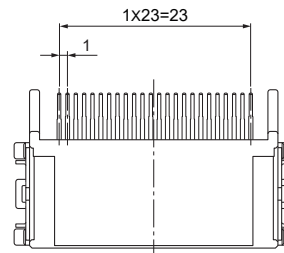

Type	Circuits	Model No.	Q'ty/box
Dual row	10	① SM10B-MECK-2GA-A-TB	200
	12	① SM12B-MECK-2GA-A-TB	200
	20	Note) ② SM20B-MECK-2TC()-A-TB	200
	24	② SM24B-MECK-2TA-A-TB	200

Material and Finish

Housing: Glass-filled LCP, black

Terminal: ① Copper alloy, nickel-undercoated

Contact area; gold-plated

Barrel area; tin-plated (reflow treatment)

② Copper alloy, nickel-undercoated, tin-plated

Note: Color/Key codes other than above-mentioned housing are also available.
Contact JST for details.

Taping specifications

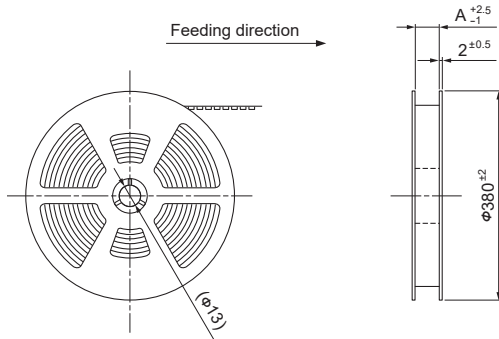

Circuits	A
10	33.5
12	45.5
20	45.5
24	57.5

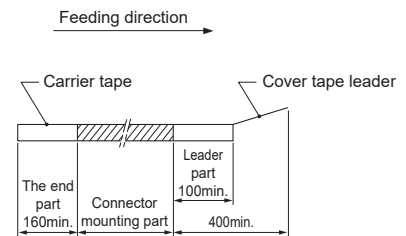

●10 circuits

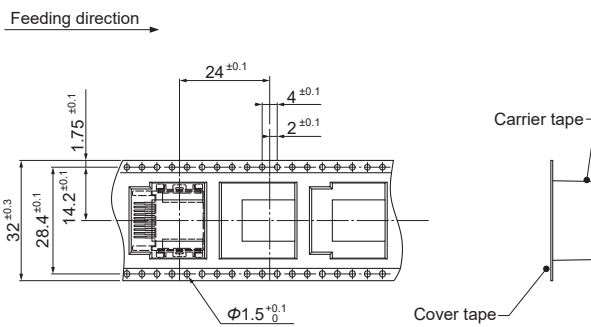

●12 circuits

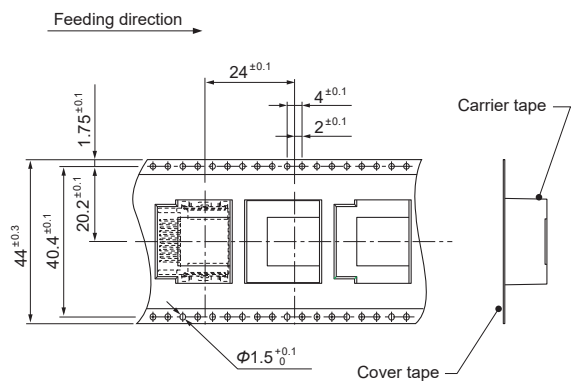

●20 circuits

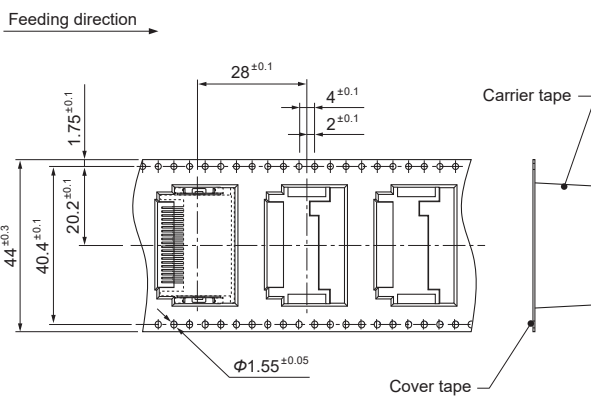

●24 circuits

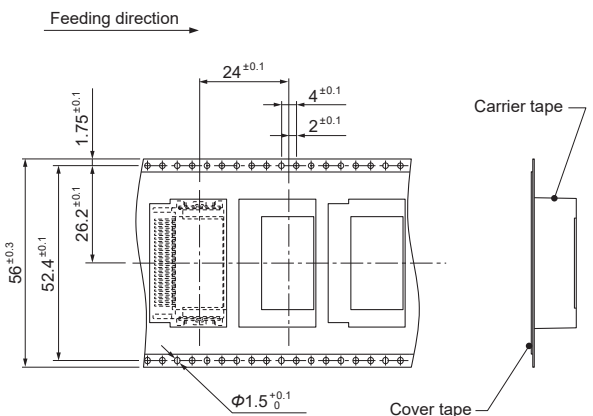

PC board layout, Assembly layout

DIP type

Single row

●5 circuits

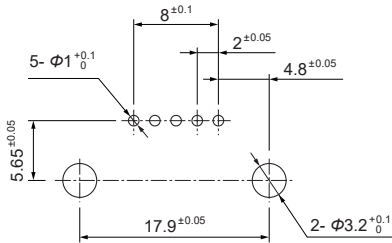

Dual row

●10 circuits

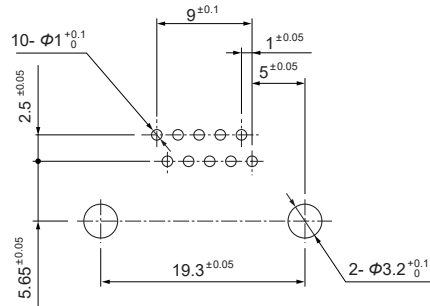

●5 circuits (plugged up)

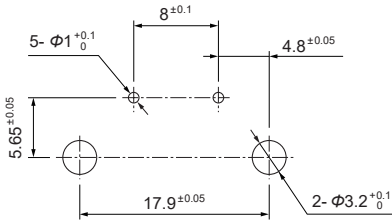

●10 circuits (plugged up)

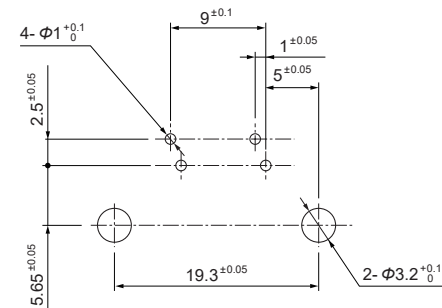

●18 (10+8) circuits

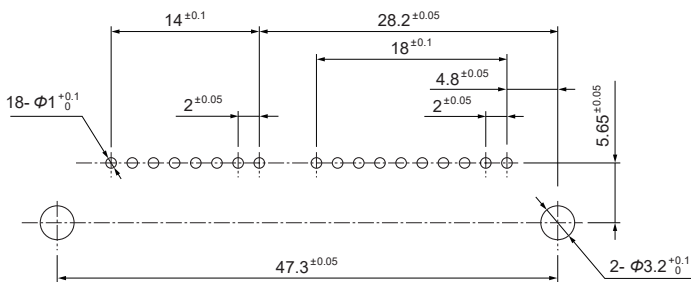

●18 circuits

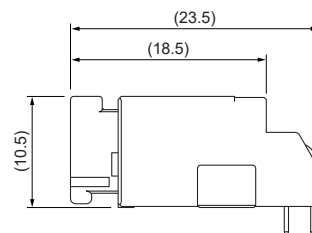
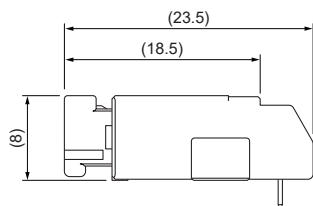
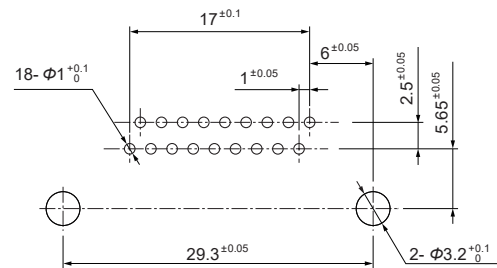

Note: 1. Tolerances are non-cumulative: ± 0.05 mm for all centers.
 2. Hole dimensions differ according to the type of PC board and piercing method.
 The dimensions above should serve as guideline. Contact JST for details.

PC board layout, Assembly layout

SMT type

Dual row

● 10 circuits

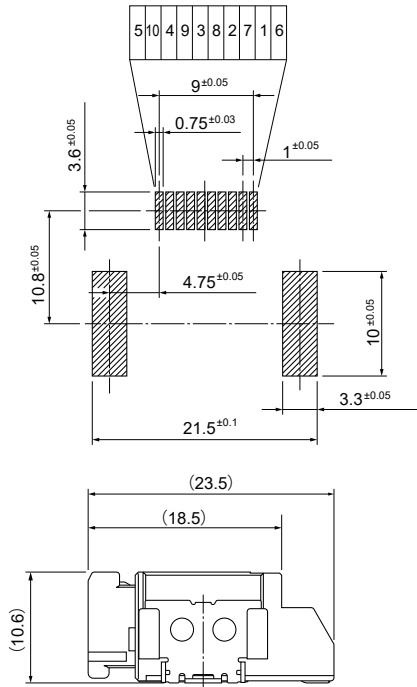

● 12 circuits

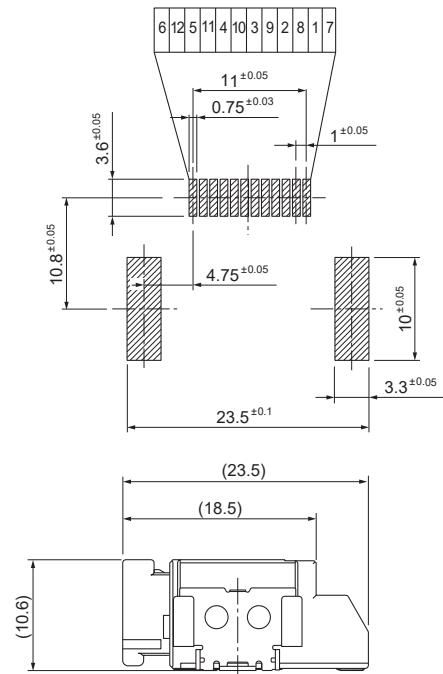

● 20 circuits

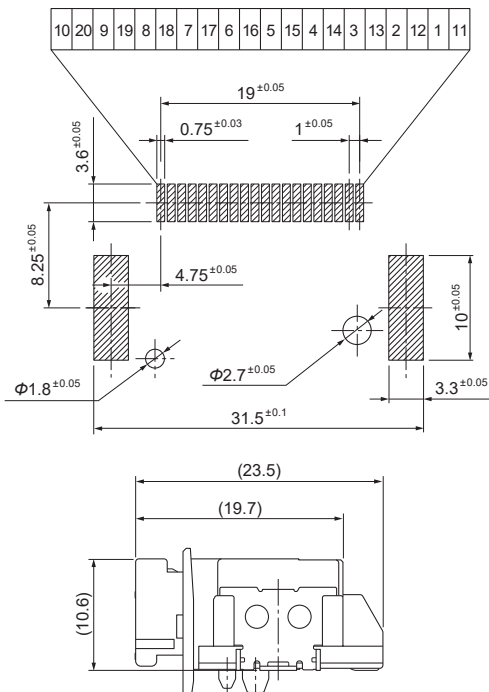

● 24 circuits

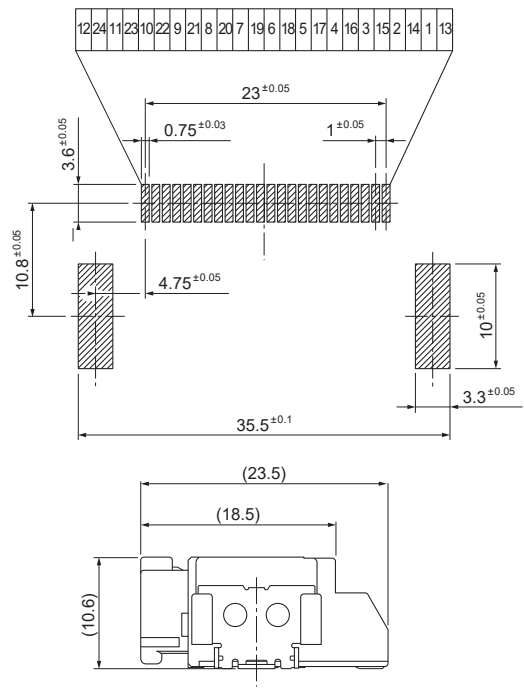

Note: Tolerances are non-cumulative: ± 0.05 mm for all centers.
The dimensions above should serve as guideline. Contact JST for details.

Crimping machine, Applicator

Strip terminal	Crimping machine	Crimp applicator MKS-L	
		Dies	Crimp applicator with dies
SMEC-A021GF-M0.5	AP-K2N	MK/SMEC-A021-05	APLMK SMEC-A021-05
SMEC-A021T-M0.5			

Note: When crimping operation is conducted using an applicator and die set other than the above, JST cannot guarantee the performance of the terminal.