

Shunt wires

SHUNT WIRE (JA type)

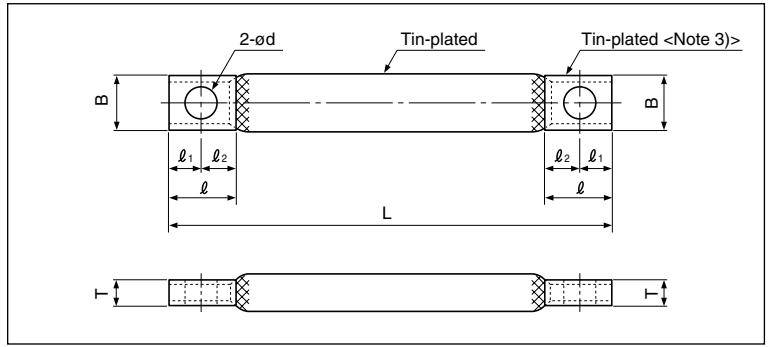

Part No.	Dimensions mm (in.)							Conductor Total Cross Sectional Area (mm ²)	Current Rating (A) (as a reference)	Strand Dia. mm (in.)
	L	ød	B	ℓ	ℓ ₁	ℓ ₂	T			
JA 1-L	—	9 (.354)	16 (.630)	18 (.709)	8 (.315)	10 (.394)	2.6 (.102)	8	67	0.12 (.005)
JA 2-L	—	9 (.354)	16 (.630)	18 (.709)	8 (.315)	10 (.394)	3.2 (.126)	16	100	
JA 3-L	—	11 (.433)	22 (.866)	24 (.945)	11 (.433)	13 (.512)	2.7 (.106)	14	100	
JA 4-L	—	11 (.433)	22 (.866)	24 (.945)	11 (.433)	13 (.512)	3.6 (.142)	28	150	
JA 5-L	—	11 (.433)	22 (.866)	24 (.945)	11 (.433)	13 (.512)	4.5 (.177)	42	190	
JA 6-L	—	14 (.551)	28(1.102)	30(1.181)	14 (.551)	16 (.630)	4.3 (.169)	44	210	
JA 7-L	—	14 (.551)	28(1.102)	30(1.181)	14 (.551)	16 (.630)	5.2 (.205)	66	270	
JA 8-L	—	14 (.551)	30(1.181)	32(1.260)	15 (.591)	17 (.669)	4.8 (.189)	60	270	
JA 9-L	—	14 (.551)	30(1.181)	32(1.260)	15 (.591)	17 (.669)	6.2 (.244)	90	350	
JA 10-L	—	18 (.709)	35(1.378)	38(1.496)	18 (.709)	20 (.787)	5.6 (.220)	76	330	
JA 11-L	—	18 (.709)	35(1.378)	38(1.496)	18 (.709)	20 (.787)	6.9 (.272)	114	420	
JA 12-L	—	18 (.709)	40(1.575)	43(1.693)	20 (.787)	23 (.906)	6.0 (.236)	100	380	
JA 13-L	—	18 (.709)	40(1.575)	43(1.693)	20 (.787)	23 (.906)	8.1 (.319)	150	480	
JA 14-L	—	18 (.709)	40(1.575)	43(1.693)	20 (.787)	23 (.906)	10.0 (.394)	200	600	
JA-2501	200 (7.874)	12 (.472)	25 (.984)	45(1.772)	20 (.787)	25 (.984)	5.0 (.197)	38	200	—
JA-2502	200 (7.874)	12 (.472)	25 (.984)	45(1.772)	20 (.787)	25 (.984)	6.4 (.252)	76	300	
JA-2503	200 (7.874)	12 (.472)	25 (.984)	45(1.772)	20 (.787)	25 (.984)	8.4 (.331)	114	380	
JA-2504	200 (7.874)	12 (.472)	25 (.984)	45(1.772)	20 (.787)	25 (.984)	10.4 (.409)	152	450	

Note: 1) The current ratings indicated in the table are reference values for a temperature rise of 50°C in the atmosphere.

These currents may change in accordance with the method of use and the ambient conditions.

2) Indicate the desired length in place of the "L" in the part number. Example: For a length of 200mm for model JA1, specify JA1-200.

3) Other plating (ex. Silver-plating) is also possible. Contact JST for details.

4) Delivery lead times may vary depending on the product. Contact JST for details.

Shunt wires

SHUNT WIRE (JB type)

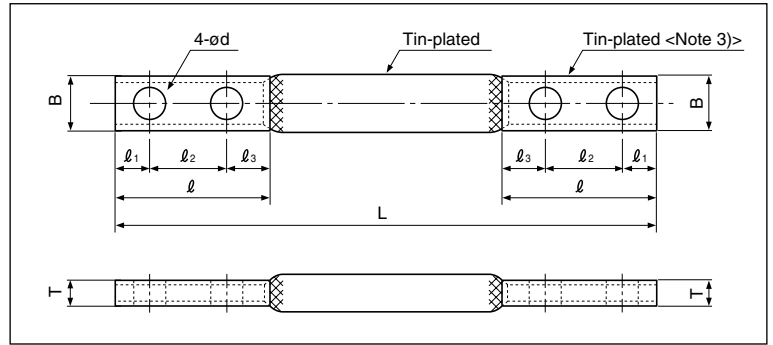

Part No.	Dimensions mm (in.)								Conductor Total Cross Sectional Area (mm ²)	Current Rating (A) (as a reference)	Strand Dia. mm (in.)
	L	ød	B	ℓ	ℓ ₁	ℓ ₂	ℓ ₃	T			
JB 1-L	—	11 (.433)	22 (.866)	50(1.969)	12.5(.492)	25 (.984)	12.5(.492)	5.5 (.217)	56	230	0.12 (.005)
JB 2-L	—	11 (.433)	22 (.866)	50(1.969)	12.5(.492)	25 (.984)	12.5(.492)	6.5 (.256)	70	270	
JB 3-L	—	11 (.433)	28(1.102)	60(2.362)	15 (.591)	30(1.181)	15 (.591)	6.5 (.256)	88	320	
JB 4-L	—	11 (.433)	28(1.102)	60(2.362)	15 (.591)	30(1.181)	15 (.591)	8.0 (.315)	110	380	
JB 5-L	—	11 (.433)	30(1.181)	60(2.362)	15 (.591)	30(1.181)	15 (.591)	7.9 (.311)	120	410	
JB 6-L	—	11 (.433)	30(1.181)	60(2.362)	15 (.591)	30(1.181)	15 (.591)	9.1 (.358)	150	450	
JB 7-L	—	14 (.551)	35(1.378)	80(3.150)	20 (.787)	40(1.575)	20 (.787)	8.8 (.346)	152	480	
JB 8-L	—	14 (.551)	35(1.378)	80(3.150)	20 (.787)	40(1.575)	20 (.787)	9.5 (.374)	190	550	
JB 9-L	—	14 (.551)	40(1.575)	80(3.150)	20 (.787)	40(1.575)	20 (.787)	10.0 (.394)	200	600	
JB 10-L	—	14 (.551)	40(1.575)	80(3.150)	20 (.787)	40(1.575)	20 (.787)	11.2 (.441)	250	670	0.18 (.007)
JB 11-L	—	18 (.709)	45(1.772)	100(3.937)	25 (.984)	50(1.969)	25 (.984)	12.5 (.492)	300	760	
JB 12-L	—	18 (.709)	45(1.772)	100(3.937)	25 (.984)	50(1.969)	25 (.984)	14.2 (.559)	360	860	
JB 13-L	—	18 (.709)	50(1.969)	100(3.937)	25 (.984)	50(1.969)	25 (.984)	13.8 (.543)	400	960	
JB 14-L	—	18 (.709)	50(1.969)	100(3.937)	25 (.984)	50(1.969)	25 (.984)	17.1 (.673)	500	1,100	
JB-4001	300 (11.811)	12 (.472)	40(1.575)	85(3.346)	20 (.787)	40(1.575)	25 (.984)	4.6 (.181)	50	290	—
JB-4002	300 (11.811)	12 (.472)	40(1.575)	85(3.346)	20 (.787)	40(1.575)	25 (.984)	6.2 (.244)	100	410	
JB-4003	300 (11.811)	12 (.472)	40(1.575)	85(3.346)	20 (.787)	40(1.575)	25 (.984)	8.5 (.335)	150	520	
JB-4004	300 (11.811)	12 (.472)	40(1.575)	85(3.346)	20 (.787)	40(1.575)	25 (.984)	10.0 (.394)	200	580	
JB-4005	300 (11.811)	12 (.472)	40(1.575)	85(3.346)	20 (.787)	40(1.575)	25 (.984)	11.6 (.457)	250	690	
JB-4006	300 (11.811)	12 (.472)	40(1.575)	85(3.346)	20 (.787)	40(1.575)	25 (.984)	13.2 (.520)	300	770	
JB-5001	330 (12.992)	14 (.551)	50(1.969)	95(3.740)	25 (.984)	40(1.575)	30 (1.181)	6.0 (.236)	100	450	
JB-5002	330 (12.992)	14 (.551)	50(1.969)	95(3.740)	25 (.984)	40(1.575)	30 (1.181)	8.5 (.335)	200	650	
JB-5003	330 (12.992)	14 (.551)	50(1.969)	95(3.740)	25 (.984)	40(1.575)	30 (1.181)	11.6 (.457)	300	820	
JB-5004	330 (12.992)	14 (.551)	50(1.969)	95(3.740)	25 (.984)	40(1.575)	30 (1.181)	14.2 (.559)	400	970	
JB-5005	330 (12.992)	14 (.551)	50(1.969)	95(3.740)	25 (.984)	40(1.575)	30 (1.181)	16.7 (.657)	500	1,100	
JB-5006	330 (12.992)	14 (.551)	50(1.969)	95(3.740)	25 (.984)	40(1.575)	30 (1.181)	19.3 (.760)	600	1,220	

- Note: 1) The current ratings indicated in the table are reference values for a temperature rise of 50°C in the atmosphere. These currents may change in accordance with the method of use and the ambient conditions.
 2) Indicate the desired length in place of the "L" in the part number. Example: For a length of 200mm for model JB1, specify JB1-200.
 3) Other plating (ex. Silver-plating) is also possible. Contact JST for details.
 4) Delivery lead times may vary depending on the product. Contact JST for details.

Shunt wires

SHUNT WIRE (JC type)

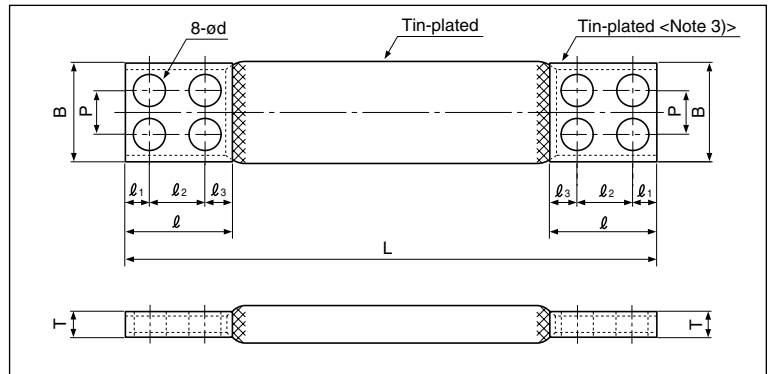

Part No.	Dimensions mm (in.)									Conductor Total Cross Sectional Area (mm ²)	Current Rating (A) (as a reference)	Strand Dia. mm (in.)
	L	ø d	B	P	l	l ₁	l ₂	l ₃	T			
JC1-L	—	14 (.551)	75 (2.953)	40 (1.575)	80 (3.150)	20 (.787)	40 (1.575)	20 (.787)	9.8 (.386)	304	940	0.12 (.005)
JC2-L	—	14 (.551)	75 (2.953)	40 (1.575)	80 (3.150)	20 (.787)	40 (1.575)	20 (.787)	11.0 (.433)	380	1,070	
JC3-L	—	14 (.551)	75 (2.953)	40 (1.575)	80 (3.150)	20 (.787)	40 (1.575)	20 (.787)	12.5 (.492)	456	1,190	
JC4-L	—	14 (.551)	75 (2.953)	40 (1.575)	80 (3.150)	20 (.787)	40 (1.575)	20 (.787)	13.5 (.531)	532	1,300	
JC5-L	—	14 (.551)	75 (2.953)	40 (1.575)	80 (3.150)	20 (.787)	40 (1.575)	20 (.787)	15.0 (.591)	608	1,420	
JC6-L	—	14 (.551)	75 (2.953)	40 (1.575)	80 (3.150)	20 (.787)	40 (1.575)	20 (.787)	16.0 (.630)	684	1,530	
JC7-L	—	18 (.709)	90 (3.543)	50 (1.969)	100 (3.937)	25 (.984)	50 (1.969)	25 (.984)	15.5 (.610)	720	1,580	0.18 (.007)
JC8-L	—	18 (.709)	90 (3.543)	50 (1.969)	100 (3.937)	25 (.984)	50 (1.969)	25 (.984)	17.0 (.669)	840	1,720	
JC9-L	—	18 (.709)	90 (3.543)	50 (1.969)	100 (3.937)	25 (.984)	50 (1.969)	25 (.984)	19.0 (.748)	960	1,880	
JC10-L	—	18 (.709)	100 (3.937)	50 (1.969)	100 (3.937)	25 (.984)	50 (1.969)	25 (.984)	18.5 (.728)	1,000	2,040	
JC11-L	—	18 (.709)	100 (3.937)	50 (1.969)	100 (3.937)	25 (.984)	50 (1.969)	25 (.984)	21.0 (.827)	1,200	2,280	
JC-7501	350 (13.780)	14 (.551)	75 (2.953)	40 (1.575)	95 (3.740)	25 (.984)	40 (1.575)	30 (1.181)	7.2 (.283)	150	680	—
JC-7502	350 (13.780)	14 (.551)	75 (2.953)	40 (1.575)	95 (3.740)	25 (.984)	40 (1.575)	30 (1.181)	8.0 (.315)	200	760	
JC-7503	350 (13.780)	14 (.551)	75 (2.953)	40 (1.575)	95 (3.740)	25 (.984)	40 (1.575)	30 (1.181)	8.8 (.346)	250	860	
JC-7504	350 (13.780)	14 (.551)	75 (2.953)	40 (1.575)	95 (3.740)	25 (.984)	40 (1.575)	30 (1.181)	9.7 (.382)	300	940	
JC-7505	350 (13.780)	14 (.551)	75 (2.953)	40 (1.575)	95 (3.740)	25 (.984)	40 (1.575)	30 (1.181)	11.4 (.449)	400	1,100	
JC-7506	350 (13.780)	14 (.551)	75 (2.953)	40 (1.575)	95 (3.740)	25 (.984)	40 (1.575)	30 (1.181)	13.0 (.512)	500	1,240	
JC-7507	350 (13.780)	14 (.551)	75 (2.953)	40 (1.575)	95 (3.740)	25 (.984)	40 (1.575)	30 (1.181)	14.6 (.575)	600	1,380	
JC-7508	350 (13.780)	14 (.551)	75 (2.953)	40 (1.575)	95 (3.740)	25 (.984)	40 (1.575)	30 (1.181)	19.0 (.748)	800	1,630	
JC-7509	350 (13.780)	14 (.551)	75 (2.953)	40 (1.575)	95 (3.740)	25 (.984)	40 (1.575)	30 (1.181)	22.5 (.886)	1,000	1,860	
JC-7510	350 (13.780)	14 (.551)	75 (2.953)	40 (1.575)	95 (3.740)	25 (.984)	40 (1.575)	30 (1.181)	26.0 (1.024)	1,200	2,070	
JC-10001	400 (15.748)	14 (.551)	100 (3.937)	50 (1.969)	105 (4.134)	25 (.984)	50 (1.969)	30 (1.181)	8.5 (.335)	200	860	—
JC-10002	400 (15.748)	14 (.551)	100 (3.937)	50 (1.969)	105 (4.134)	25 (.984)	50 (1.969)	30 (1.181)	9.1 (.358)	250	970	
JC-10003	400 (15.748)	14 (.551)	100 (3.937)	50 (1.969)	105 (4.134)	25 (.984)	50 (1.969)	30 (1.181)	9.7 (.382)	300	1,060	
JC-10004	400 (15.748)	14 (.551)	100 (3.937)	50 (1.969)	105 (4.134)	25 (.984)	50 (1.969)	30 (1.181)	11.0 (.433)	400	1,240	
JC-10005	400 (15.748)	14 (.551)	100 (3.937)	50 (1.969)	105 (4.134)	25 (.984)	50 (1.969)	30 (1.181)	12.2 (.480)	500	1,380	
JC-10006	400 (15.748)	14 (.551)	100 (3.937)	50 (1.969)	105 (4.134)	25 (.984)	50 (1.969)	30 (1.181)	13.5 (.531)	600	1,530	
JC-10007	400 (15.748)	14 (.551)	100 (3.937)	50 (1.969)	105 (4.134)	25 (.984)	50 (1.969)	30 (1.181)	16.0 (.630)	800	1,800	
JC-10008	400 (15.748)	14 (.551)	100 (3.937)	50 (1.969)	105 (4.134)	25 (.984)	50 (1.969)	30 (1.181)	18.5 (.728)	1,000	2,000	
JC-10009	400 (15.748)	14 (.551)	100 (3.937)	50 (1.969)	105 (4.134)	25 (.984)	50 (1.969)	30 (1.181)	21.6 (.850)	1,250	2,200	
JC-10010	400 (15.748)	14 (.551)	100 (3.937)	50 (1.969)	105 (4.134)	25 (.984)	50 (1.969)	30 (1.181)	25.0 (.984)	1,500	2,500	

Note:1) The current ratings indicated in the table are reference values for a temperature rise of 50°C in the atmosphere.

These currents may change in accordance with the method of use and the ambient conditions.

2) Indicate the desired length in place of the "L" in the part number. Example: For a length of 200mm for model JC1, specify JC1-200.

3) Other plating (ex. Silver-plating) is also possible. Contact JST for details.

4) Delivery lead times may vary depending on the product. Contact JST for details.

Shunt wires

SHUNT WIRE (JD type)

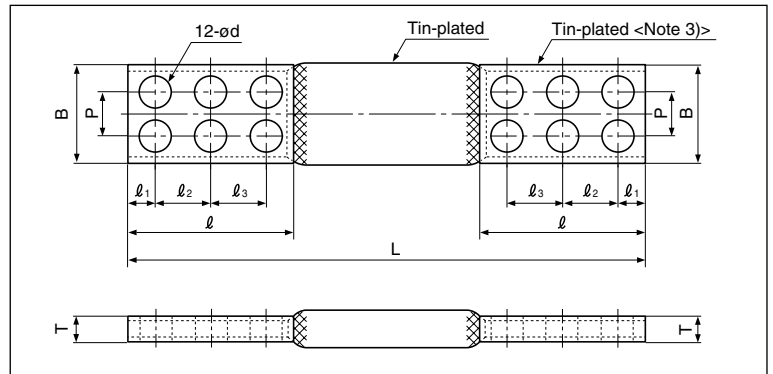

Part No.	Dimensions mm (in.)									Conductor Total Cross Sectional Area (mm ²)	Current Rating (A) (as a reference)	Strand Dia. mm (in.)
	L	ø d	B	P	l	l ₁	l ₂	l ₃	T			
JD1-L	—	18 (.709)	100 (3.937)	50 (1.969)	150 (5.906)	25 (.984)	50 (1.969)	50 (1.969)	25.0 (.984)	1,400	2,500	0.18 (.007)
JD2-L	—	18 (.709)	100 (3.937)	50 (1.969)	150 (5.906)	25 (.984)	50 (1.969)	50 (1.969)	28.0(1.102)	1,600	2,700	
JD3-L	—	18 (.709)	100 (3.937)	50 (1.969)	150 (5.906)	25 (.984)	50 (1.969)	50 (1.969)	30.5(1.201)	1,800	2,900	

Note: 1) The current ratings indicated in the table are reference values for a temperature rise of 50°C in the atmosphere.

These currents may change in accordance with the method of use and the ambient conditions.

2) Indicate the desired length in place of the "L" in the part number. Example: For a length of 200mm for model JD1, specify JD1-200.

3) Other plating (ex. Silver-plating) is also possible. Contact JST for details.

4) Delivery lead times may vary depending on the product. Contact JST for details.

Shunt wires

SHUNT WIRE (JE type)

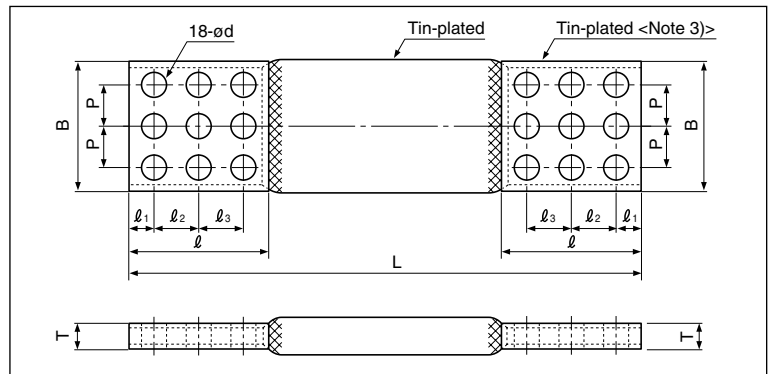

Part No.	Dimensions mm (in.)									Conductor Total Cross Sectional Area (mm ²)	Current Rating (A) (as a reference)	Strand Dia. mm (in.)
	L	ø d	B	P	l	l ₁	l ₂	l ₃	T			
JE1-L	—	14 (.551)	120 (4.724)	40 (1.575)	120 (4.724)	20 (.787)	40 (1.575)	40 (1.575)	26.5(1.043)	1,800	3,200	0.18 (.007)
JE2-L	—	14 (.551)	120 (4.724)	40 (1.575)	120 (4.724)	20 (.787)	40 (1.575)	40 (1.575)	30.2(1.189)	2,160	3,450	
JE3-L	—	18 (.709)	150 (5.906)	50 (1.969)	150 (5.906)	25 (.984)	50 (1.969)	50 (1.969)	25.5(1.004)	2,100	3,600	
JE4-L	—	18 (.709)	150 (5.906)	50 (1.969)	150 (5.906)	25 (.984)	50 (1.969)	50 (1.969)	31.5(1.240)	2,700	4,000	

Note: 1) The current ratings indicated in the table are reference values for a temperature rise of 50°C in the atmosphere.

These currents may change in accordance with the method of use and the ambient conditions.

2) Indicate the desired length in place of the "L" in the part number. Example: For a length of 200mm for model JE1, specify JE1-200.

3) Other plating (ex. Silver-plating) is also possible. Contact JST for details.

4) Delivery lead times may vary depending on the product. Contact JST for details.

Shunt wires

SHUNT WIRE (JF type)

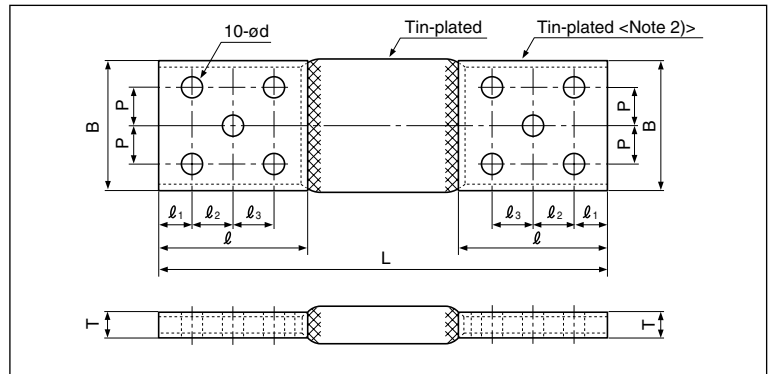

Part No.	Dimensions mm (in.)									Conductor Total Cross Sectional Area (mm ²)	Current Rating (A) (as a reference)	Strand Dia. mm (in.)
	L	ø d	B	P	l	l ₁	l ₂	l ₃	T			
JF-15001	500(19.685)	18 (.709)	150 (5.906)	50 (1.969)	165 (6.496)	30 (1.181)	50 (1.969)	50 (1.969)	9.6 (.378)	400	1,460	—
JF-15002	500(19.685)	18 (.709)	150 (5.906)	50 (1.969)	165 (6.496)	30 (1.181)	50 (1.969)	50 (1.969)	10.5 (.413)	500	1,640	
JF-15003	500(19.685)	18 (.709)	150 (5.906)	50 (1.969)	165 (6.496)	30 (1.181)	50 (1.969)	50 (1.969)	11.5 (.453)	600	1,800	
JF-15004	500(19.685)	18 (.709)	150 (5.906)	50 (1.969)	165 (6.496)	30 (1.181)	50 (1.969)	50 (1.969)	13.5 (.531)	800	2,100	
JF-15005	500(19.685)	18 (.709)	150 (5.906)	50 (1.969)	165 (6.496)	30 (1.181)	50 (1.969)	50 (1.969)	15.5 (.610)	1,000	2,350	
JF-15006	500(19.685)	18 (.709)	150 (5.906)	50 (1.969)	165 (6.496)	30 (1.181)	50 (1.969)	50 (1.969)	17.5 (.689)	1,200	2,600	
JF-15007	500(19.685)	18 (.709)	150 (5.906)	50 (1.969)	165 (6.496)	30 (1.181)	50 (1.969)	50 (1.969)	21.0 (.827)	1,600	3,000	
JF-15008	500(19.685)	18 (.709)	150 (5.906)	50 (1.969)	165 (6.496)	30 (1.181)	50 (1.969)	50 (1.969)	25.0 (.984)	2,000	3,400	
JF-15009	500(19.685)	18 (.709)	150 (5.906)	50 (1.969)	165 (6.496)	30 (1.181)	50 (1.969)	50 (1.969)	28.5(1.122)	2,400	3,800	
JF-15010	500(19.685)	18 (.709)	150 (5.906)	50 (1.969)	165 (6.496)	30 (1.181)	50 (1.969)	50 (1.969)	32.5(1.280)	2,800	4,100	

Note:1) The current ratings indicated in the table are reference values for a temperature rise of 50°C in the atmosphere.

These currents may change in accordance with the method of use and the ambient conditions.

2) Other plating (ex. Silver-plating) is also possible. Contact JST for details.

3) Delivery lead times may vary depending on the product. Contact JST for details.

Shunt wires

SHUNT WIRE (JG type)

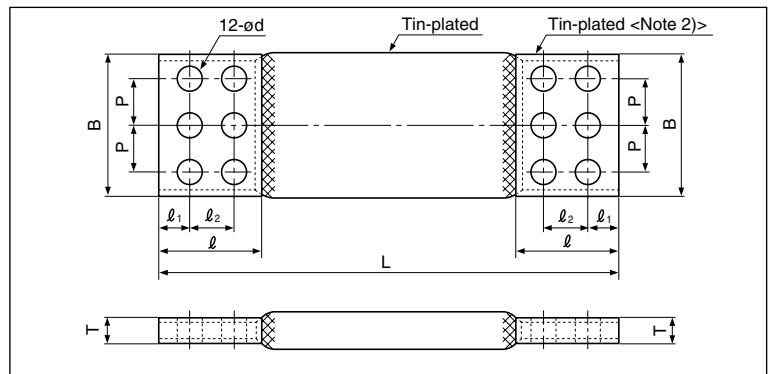

Part No.	Dimensions mm (in.)								Conductor Total Cross Sectional Area (mm ²)	Current Rating (A) (as a reference)	Strand Dia. mm (in.)
	L	ø d	P	B	l	l ₁	l ₂	T			
JG-20001	550(21.654)	18 (.709)	60 (2.362)	200 (7.874)	165 (6.496)	30 (1.181)	100 (3.937)	10.0 (.394)	500	1,850	—
JG-20002	550(21.654)	18 (.709)	60 (2.362)	200 (7.874)	165 (6.496)	30 (1.181)	100 (3.937)	12.0 (.472)	800	2,360	
JG-20003	550(21.654)	18 (.709)	60 (2.362)	200 (7.874)	165 (6.496)	30 (1.181)	100 (3.937)	13.5 (.531)	1,000	2,640	
JG-20004	550(21.654)	18 (.709)	60 (2.362)	200 (7.874)	165 (6.496)	30 (1.181)	100 (3.937)	15.0 (.591)	1,200	2,900	
JG-20005	550(21.654)	18 (.709)	60 (2.362)	200 (7.874)	165 (6.496)	30 (1.181)	100 (3.937)	17.0 (.669)	1,500	3,200	
JG-20006	550(21.654)	18 (.709)	60 (2.362)	200 (7.874)	165 (6.496)	30 (1.181)	100 (3.937)	20.5 (.807)	2,000	3,800	
JG-20007	550(21.654)	18 (.709)	60 (2.362)	200 (7.874)	165 (6.496)	30 (1.181)	100 (3.937)	24.0 (.945)	2,500	4,200	
JG-20008	550(21.654)	18 (.709)	60 (2.362)	200 (7.874)	165 (6.496)	30 (1.181)	100 (3.937)	27.5(1.083)	3,000	4,700	
JG-20009	550(21.654)	18 (.709)	60 (2.362)	200 (7.874)	165 (6.496)	30 (1.181)	100 (3.937)	31.0(1.220)	3,500	5,100	

Note:1) The current ratings indicated in the table are reference values for a temperature rise of 50°C in the atmosphere.

These currents may change in accordance with the method of use and the ambient conditions.

2) Other plating (ex. Silver-plating) is also possible. Contact JST for details.

3) Delivery lead times may vary depending on the product. Contact JST for details.

Shunt wires

SHUNT WIRE (For pantagraph)

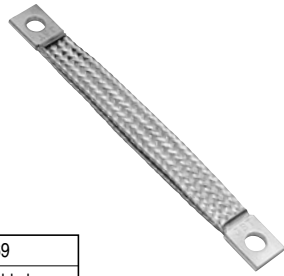

JRS Dwg. No.	ED76169
Wire used	0.12x14mm ² double layers
Terminal material	CuT

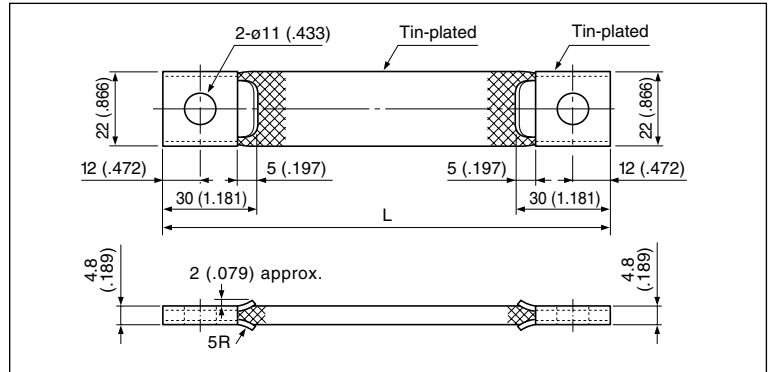

Type	Part No.	L	Remarks (parts to be applied to)
1	JR1-210	210	PS13C, 14A, 16, 16B, 16C, 16D, 16H, 17, 19, 19A, 21, 100A, 100B, 100C, 101, 101B, 101C, 102A, 102B
2	JR2-250	250	PS13C, 15, 16, 16B, 16C, 16D, 16H, 17, 19, 19A, 21, 100A, 100B, 100C, 101, 101B, 101C, 102A, 102B
3	JR3-290	290	PS13C
4	JR4-330	330	PS15C
5	JR5-360	360	PS14C

Note:1) Delivery lead times may vary depending on the product. Contact JST for details.